

Sizes		CHOPOK L 120 VD 1270/450 TV	CHOPOK L 120 VD 1270/510 TV
1	A	mm	1270
2	F	mm	1425
3	C	mm	610
4	DN	Ø mm	200
5	B	mm	450
6	V	mm	1380
7	J	mm	325 + /160/
8	L	Ø mm	125
9	N	mm	50
10	FF	mm	1390
11	H	mm	315
12	NN	mm	
13	M	mm	20
14	H	mm	315

Basic design:

Thermodynamic Hearth
 Segment chamotte lining (SO)
 Glass Classic
 Inox control grip-handle RP2
 Enviromentally friendly varnish
 Inspection hole side

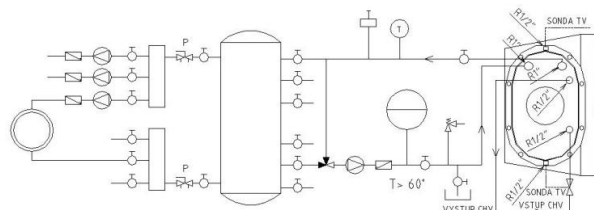

Technical parameters			
1	Nominal heat output	kW	19
2	Nominal heat output do vody	kW	9,2
3	Water volume in heat exchanger	l	22
4	Pressure required	Pa	12
5	Maximum operating pressure	bar	2,5
6	Average efficiency	%	84,7
7	Average flue gas temperature	°C	189
8	Wood consuption	kg/h	5,9
9	Consumption of combustion air	m ³ /h	57,0
10	Emission of CO to 13% O ₂	%	0,12
11	Flue gas mass flow	g/s	19,2
12	Weight	kg	520
13	Required min. cross section for circulating air - INPUT	cm ²	300
14	Required min. cross section for circulating air - OUTPUT	cm ²	500
15	Three-component insulated chimney - active height 6 m	Ø cm	200
16	Character of building const-ruction	warm air convection	Yes
	with fireplace insert	heat storage without conv	No

Optional accessories:

Cover frame (KR)
 Glass Reflex (SR)
 Black printed glass(SM)
 Black printed glass Reflex (SMR)
 External ashtray (VOP)
 Vertical heat-storing panel (AZ)
 Inspection hole front, rear
 Rear feeding door (PD)

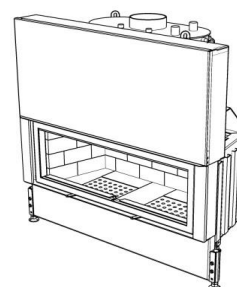

Test Method: ČSN EN 1322/A2:2007, FprEN16510-1, FprEN16510-2-2

Fireplace complies with the requirements: EN 13229, DIN +, BImSchV-Stufe 2, Commission Regulation (EU) č. 2015/1185 Ecodesign requirements

KOBOK reserves the right to change dimensions and parameters described in these sheets. The current edition can be downloaded from www.KOBOK.sk

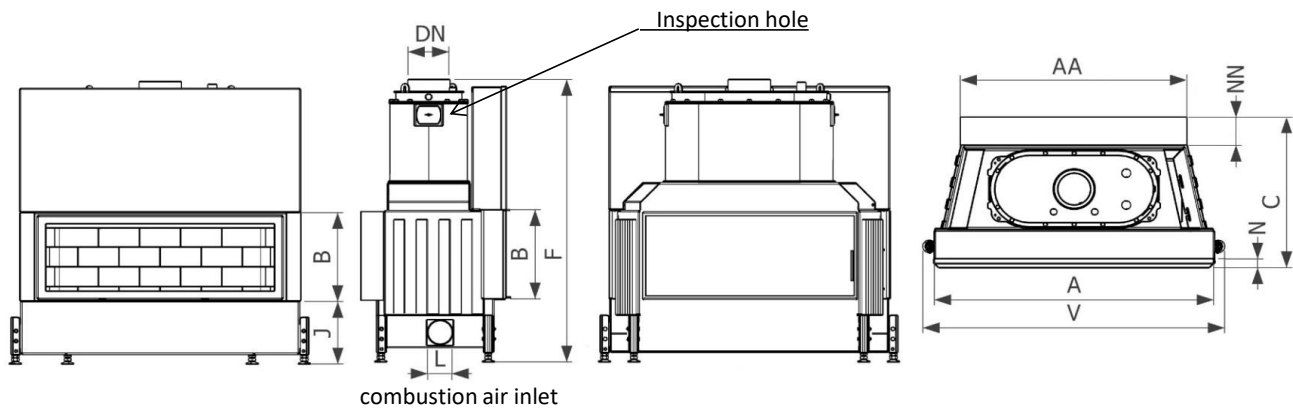

Sizes			CHOPOK L 120 VD 1270/450 TV PD 1000/450	CHOPOK L 120 VD 1270/510 TV PD 1000/510
1	A	mm	1270	
2	F	mm	1425	1485
3	C	mm	655	
4	DN	Ø mm	200	
5	B	mm	450	510
6	V	mm	1380	
7	J	mm	325 + /160/	
8	L	Ø mm	125	
9	N	mm		
10	FF	mm	1390	1450
11	AA	mm	1000	
12	NN	mm	70	
13	M	mm	20	
14	H	mm	315	375

Basic design:

Thermodynamic Hearth
 Seg. chamotte lining
 Glass Classic
 Inox control grip-handle RP2 (MP2)
 Enviromentally friendly varnish
 Inspection hole side

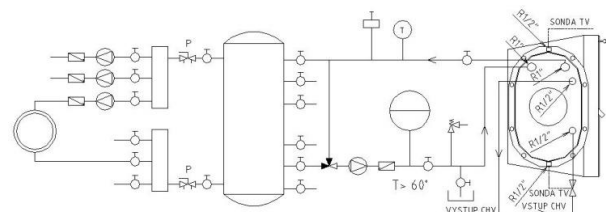

Technical parameters			
1	Nominal heat output	kW	19
2	Nominal heat output do vody	kW	9,2
3	Water volume in heat exchanger	l	22
4	Pressure required	Pa	12
5	Maximum operating pressure	bar	2,5
6	Average efficiency	%	84,7
7	Average flue gas temperature	°C	189
8	Wood consuption	kg/h	5,9
9	Consumption of combustion air	m3/h	57,0
10	Emission of CO to 13% O2	%	0,12
11	Flue gas mass flow	g/s	19,2
12	Weight	kg	520
13	Required min. cross section for circulating air - INPUT	cm ²	300
14	Required min. cross section for circulating air - OUTPUT	cm ²	500
15	Three-component insulated chimney - active height 5 m	Ø cm	200
16	Character of building const-ruction	warm air convection	Yes
	with fireplace insert	heat storage without conv	No

Optional accessories:

Cover frame (KR)
 Glass Reflex (SR)
 Black printed glass(SM)
 Black printed glass Reflex (SMR)
 External ashtray (VOP)
 Vertical heat-storing panel (AZ)
 Inspection hole front, rear
 Rear feeding door with glass (PDS)

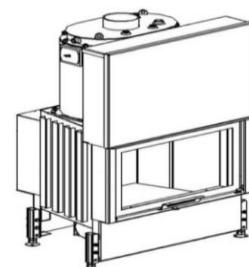

Test Method: ČSN EN 1322/A2:2007, FprEN16510-1, FprEN16510-2-2

Fireplace complies with the requirements: EN 13229, DIN +, BImSchV-Stufe 2, Commission Regulation (EU) č. 2015/1185 Ecodesign requirements

KOBOK reserves the right to change dimensions and parameters described in these sheets. The current edition can be downloaded from www.KOBOK.sk